



Sonic QuadAir

Air Hockey Table Owners Manual

Assembly operation and care instructions.

Serial # _____

Distributed By _____

Sales Person _____

Technical Service # _____



Forward

First, we would like to thank you very much for purchasing the QuadAir from Barron Games International. [This product is a multi-player game for an entertainment centerpiece.]

For your own safety, please read through this instruction manual that we have prepared for you thoroughly, and take precautions when using the product. We hope that you will become accustomed to the product quickly.

Note before assembling

1. Inspect to make sure all of the parts are included and not damaged.
2. Prior to assembly, you must ensure there is sufficient space for placing or shifting this product.
3. QuadAir needs at least 6 people for assembly and ensure your safety and the safety of others around you when moving the product.

Tools required for assembling

- QuadAir Manual
- Screw Driver or Drill
- Scissors
- QuadAir Door Key [located inside the table]

*Note: Prepare the above specified tools. Be careful not to damage the product while using these tools

Assembly Procedures

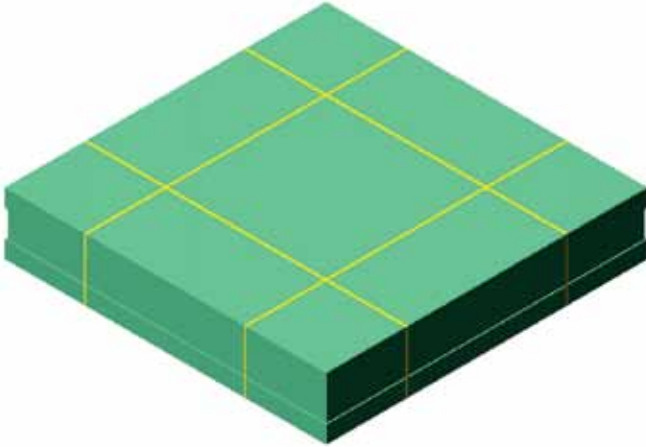

1. Use scissors or a knife to cut* through the packing tape.
**Do not cut too deep or you will damage the unit.*

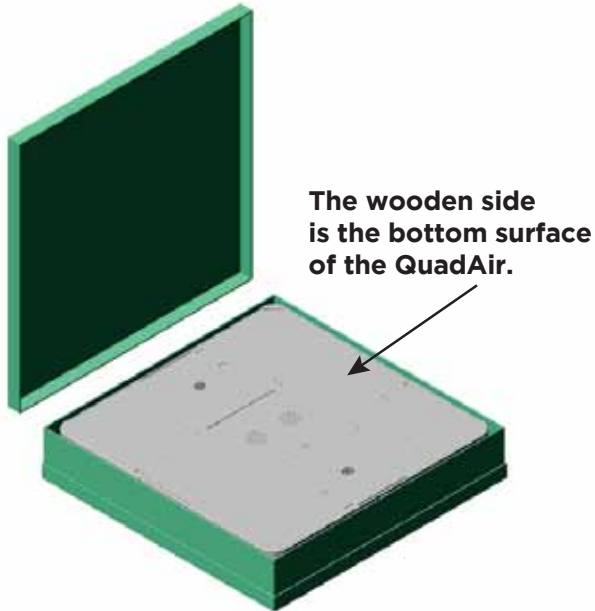

2. Open the cardboard box to ensure the wooden side is facing up and the playfield is facing down to the floor.

Use a screw driver or drill to unscrew the 4 screws on the panel with the sticker "PARTS" on it. Once the panel is opened, please take out the parts indicated below.

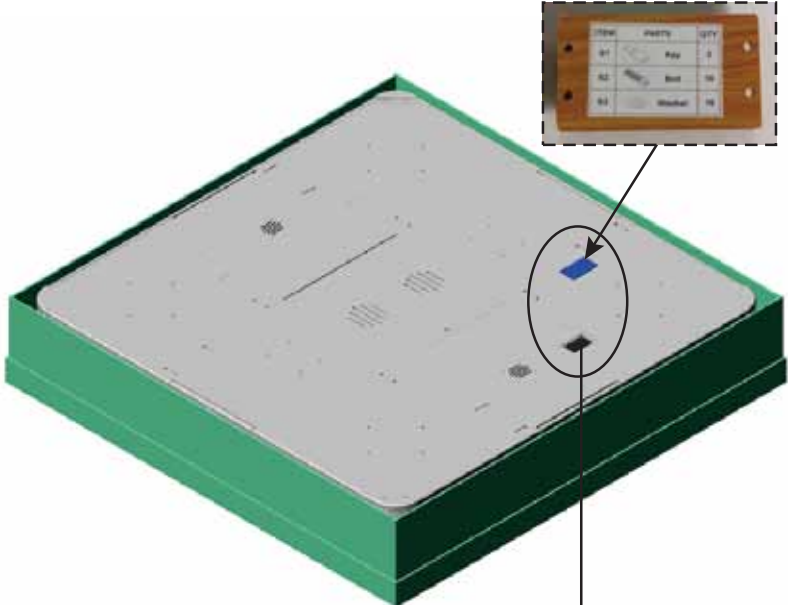

For Legs
16 Roundhead screws M8x25
16 Flat washers M8x16

For machine
3 serial number 2868
QuadAir keys

After taking out the keys, open the center door panel, and take out all other parts from inside of the machine's body.

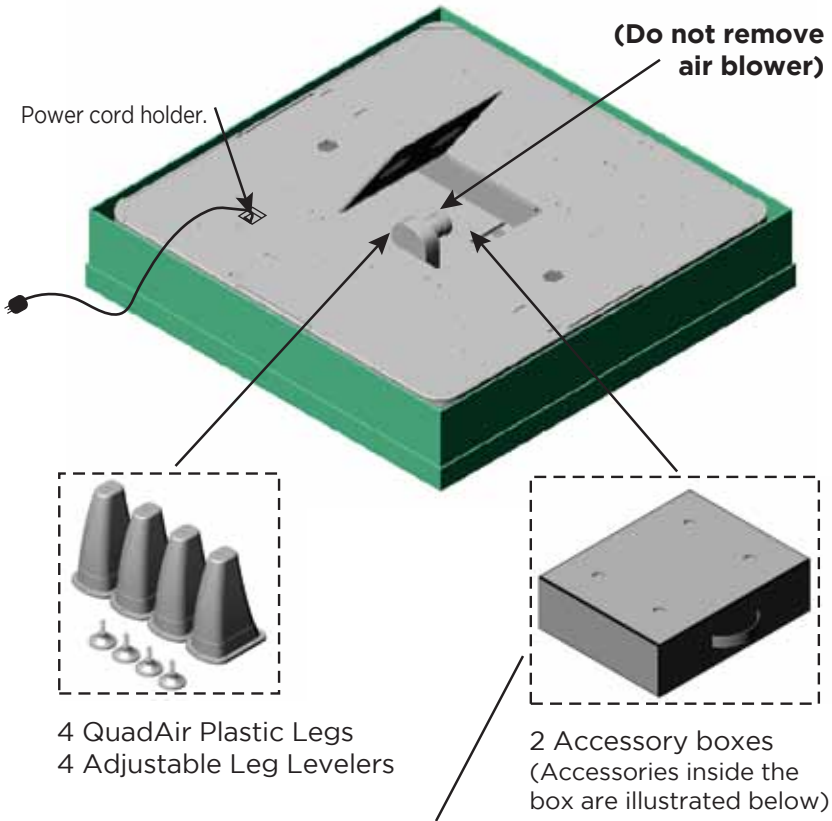

20 Pucks

+



2 Red Mallets

+



2 Blue Mallets



1 Polish Spray Wax

+



1 AC power cord

Take out the 4 QuadAir plastic legs and screw the adjustable leg levelers onto the base of the legs. Place the legs on the bottom surface of the table. Ensure alignment and then attach with the big flathead screw M5x35 and washer M8x16. **Make sure grey surface is facing out.*

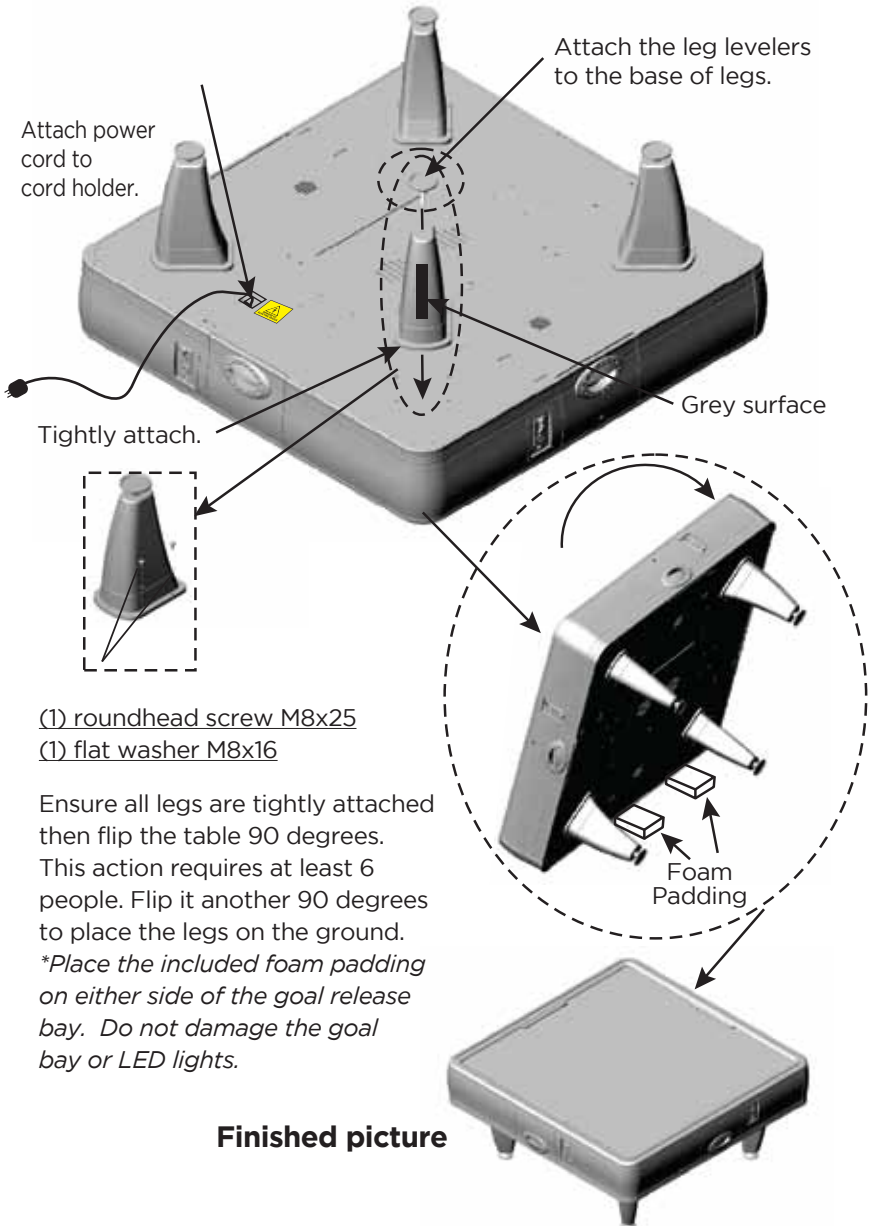

- (1) roundhead screw M8x25
- (1) flat washer M8x16

Ensure all legs are tightly attached then flip the table 90 degrees. This action requires at least 6 people. Flip it another 90 degrees to place the legs on the ground. **Place the included foam padding on either side of the goal release bay. Do not damage the goal bay or LED lights.*



Safety Instructions for use and play.



Risk of Electric Shock

- Hazardous voltage which can cause electrical shock exists inside the equipment. Only qualified personnel should work inside the equipment.



Playing Warnings

- Do not hit the puck with the mallet when the puck is not level and flat.
- Spectators should not stand by the side of the table. This may cause injury.
- Hold the mallet by the handle and not the base or the puck may hit fingers.
- This game features flashing lights which may not be suitable for photosensitive epilepsy.

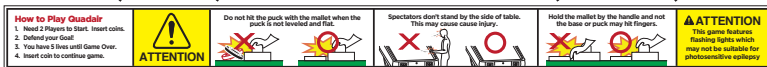
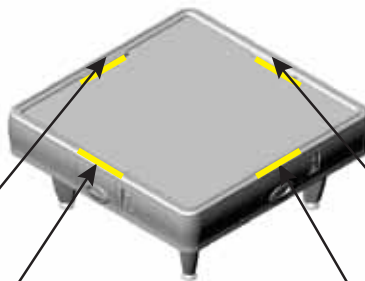

Warning labels are attached by the goal of each side.

How to Play QuadAir

1. Need 2 Players to Start. Insert credits.
2. Defend your Goal! You have 5 lives.
3. After 5 lives Game Over. Time is limited.
4. Insert coin to continue game.



ATTENTION



**BEWARE OF
ELECTRIC SHOCK**

**Do not hit the puck with the mallet when the
puck is not level and flat.**

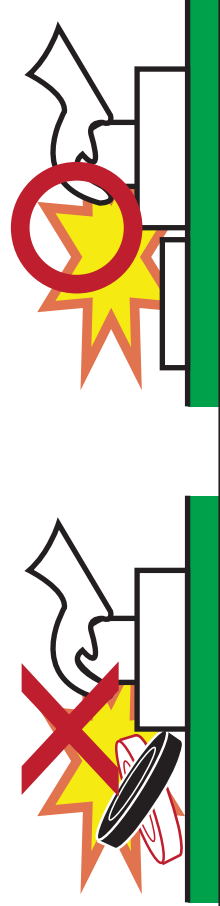

⚠ ATTENTION

**This game features
flashing lights which
may not be suitable for
photosensitive epilepsy**

**Spectators should not stand by the side of
table. This may cause injury.**

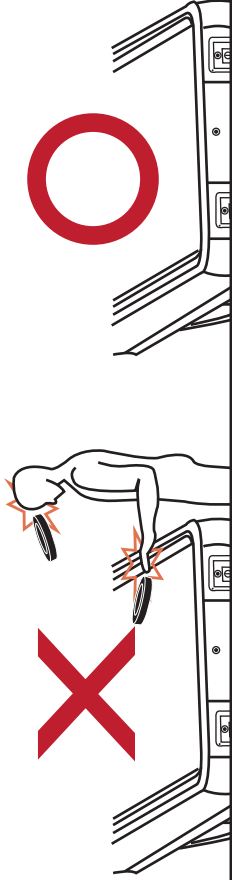

**Hold the mallet by the handle and not
the base or puck may hit fingers.**



Manual for the software of the machine

First, ensure the power is off. Open the door with a key. Hold the panel's handle and pull it out until half of the power panel is exposed.

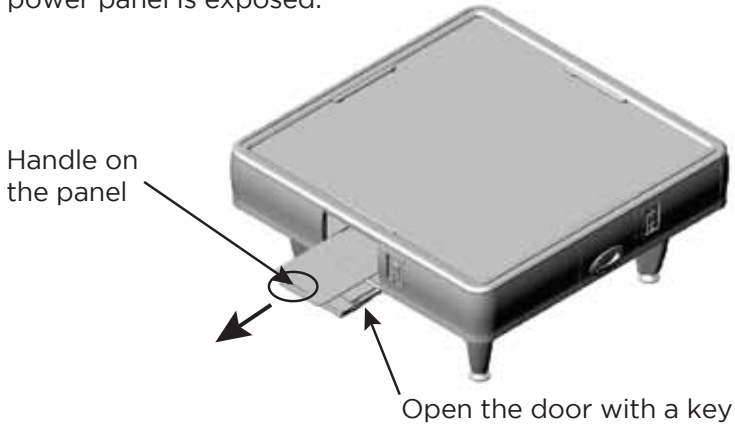

Descriptions of internal hardware

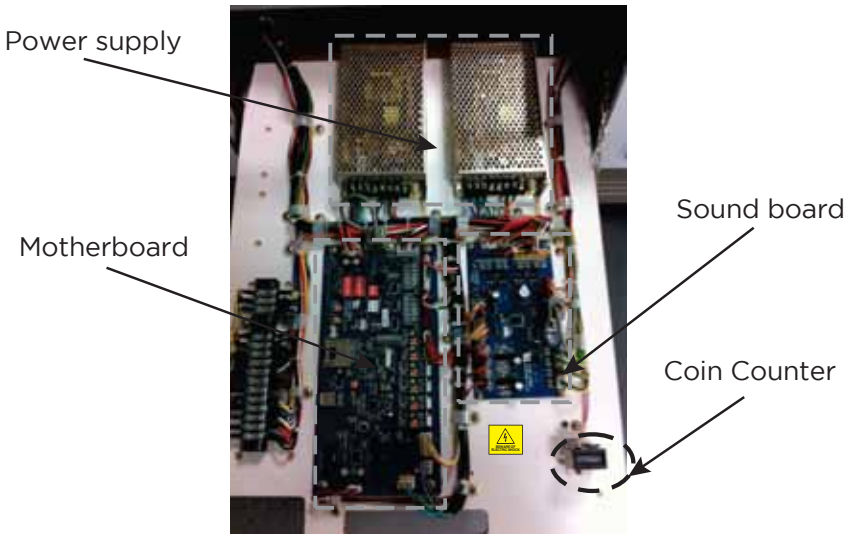

Note: Do not touch open terminals or exposed wires while the game is on. Risk of electric shock.

Function Descriptions of all hardware

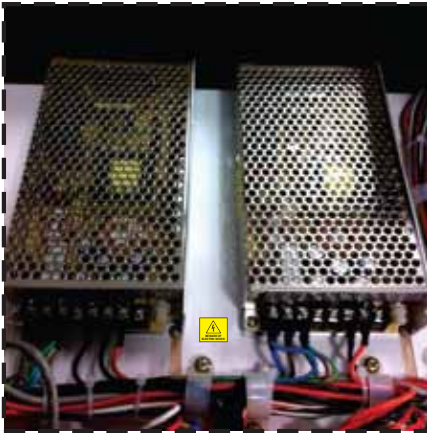

Note: Avoid electric shock. Do not touch open terminals or exposed wires. Please turn off the game to perform repairs.

Power Supply

Provides power to all internal components, such as the motherboard, coin mechanism, motor... etc. The +5v and +12v are separated to ensure no interference to components when one has an insufficient supply or an unstable supply of power.

Note: +5v is on the left +12v is on the right



Motherboard

Controls the operation of all internal components. Malfunctions or errors with any of the components can be diagnosed by looking at the LED light indicators on the motherboard.

Descriptions of light signals and DIP Switches

Error Lights

- Light A Goal Sensor Signal
- Light B Start Button Light Signal
- Light C Coin Mechanism Light Signal
- Light D Ticket Light Signal
- Light E Rail Noise Strike Light signal

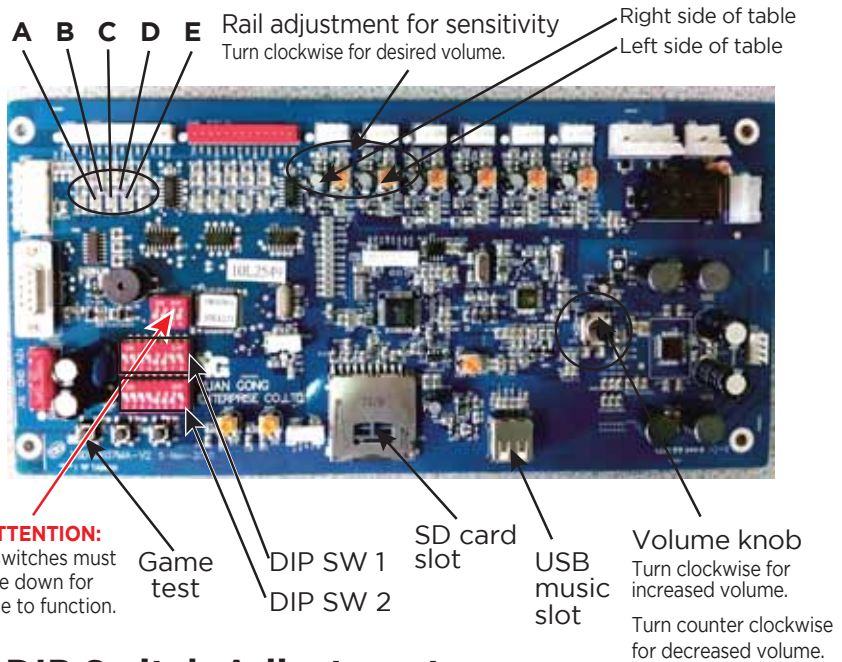

DIP Switch Adjustment

SW1 - Dip Switch 1

DIP	SW1	1	2	3	4	5	6	7	8
COINS	CREDITS	I	I	I					
1	2	O	I	I					
1	3	I	O	I					
1	4	O	O	I					
2	1	I	I	O					
3	1	O	I	O					
4	1	I	O	O					

I = UP O = DOWN

***Default switch position is down.**

SW2 - Dip Switch 2

DIP	SW2	1	2	3	4	5	6	7	8
LIFE	5	O	O	O					
	5	I	O	O					
	5	O	I	O					
	5	I	I	O					
	5	O	O	I					
	5	I	O	I					
	4	O	I	I					
	3	I	I	I					
TIME	NO LIMIT				O	O	O		
	10				I	O	O		
	8				O	I	O		
	6				I	I	O		
	4				O	O	I		
	3				I	O	I		
	2				O	I	I		
	1				I	I	I		

Description of Motherboard Controls

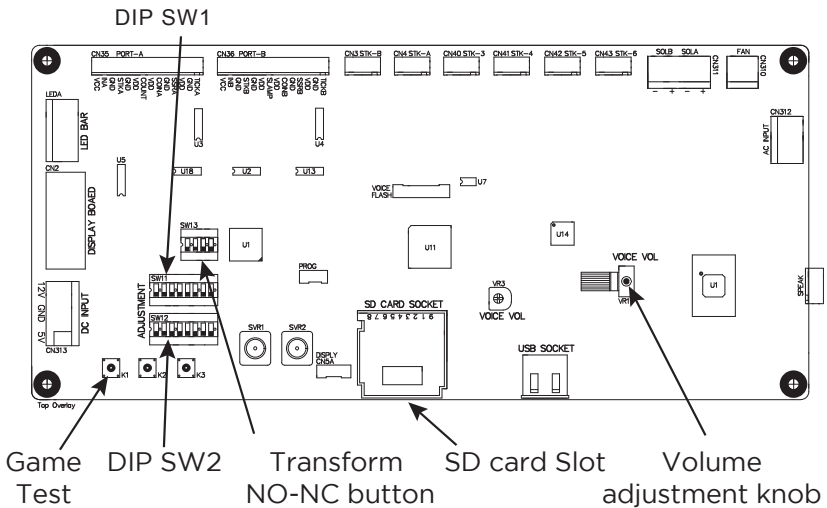

- LEDA: Running LED lights around table
- NC2 : Display panel connection outlet
- NC313 : Direct Current (DC) Input outlet
- NC35 : A1 Output Control point
- NC36 : B1 Output Control point
- NC311 : Electro-magnet switch for goal gates (solenoid)
- Nc3 : Rail Strike Detector
- NC4 : Rail Strike Detector
- NC40 : Rail Strike Detector
- NC41 : Rail Strike Detector
- NC42 : Rail Strike Detector
- NC43 : Strike Detector
- NC310 : Blower output
- NC312 : Alternating Current (AC) Output
- R3 : Sound Effect and Volume adjustment
- VF1 : Total Volume Adjustment
- SPEAK : Sound Output

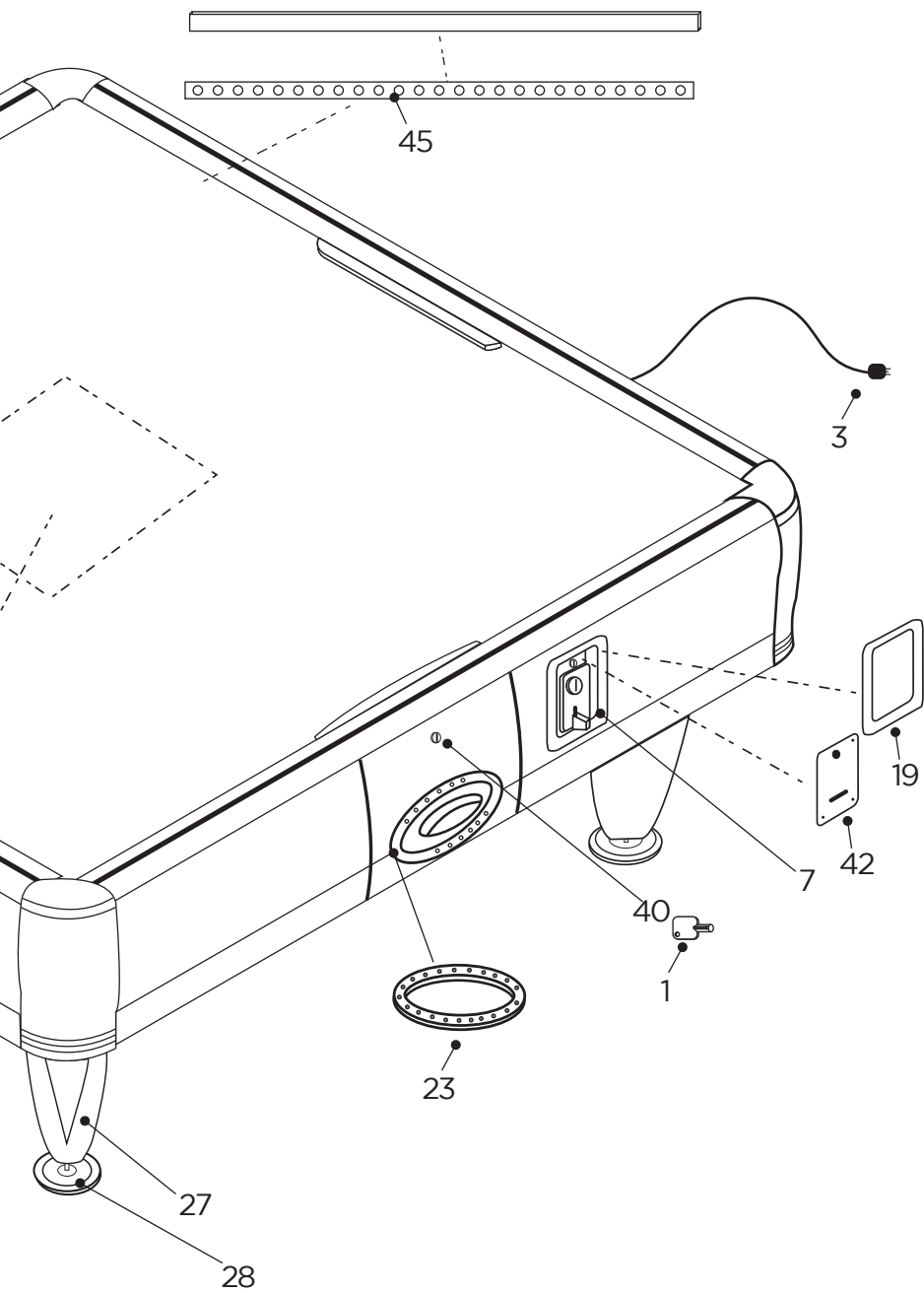

Ref #	Part #	Description	Qty
1	3202004	Air Hockey Key #2868	3
2	3213082	Solenoid Brackets	12
3	3601007	Power Cord (U.S. Style)	1
4	3604056	QuadAir Coin Mech w/LED Indicator	4
5	3605091	Goal Solenoid DC 12V	8
6	3605117	Power Supply NES-100-12+12V	1
7	3605118	Power Supply NES-100-5+5V	1
8	3607050	Blower Motor 110V	1
9	3611010	Speaker	2
10	3612370	Optical Goal Sensor	4
11	3619007	Rail Sensor Chip (27mm)	4
12	3699001	6 Digit Coin & Ticket Counter (12V)	1
13	3699019	Power Switch	1
14	3207443	Coin Panel 419mm	2
15	3212075	Door Chain 410mm	4
16	3213349	Puck Terminal	4
17	3213365	Power Switch Box	1
18	3213501	Rail Corner Reinforcement Iron	4
19	3301288	Coin & Ticket Chrome Door Accent	4
20	3301292	Access Door Spacers	8
21	3301311	Interior Corner Part Attachment	4
22	3301320	Body Corner Piece-327mm	4
23	3301347	Puck Release Bay (plastic only)	4
24	3303648	Puck Slide (362 x 200 x 8mm)	4
25	3399146	Puck Release Bay Hammer	4

Ref #	Part #	Description	Qty
26	3501053	QuadAir Black Rubber Perimeter Rail Trim	1
27	616030028	Leg Leveler	4
28	616030029	Air Hockey Leg (400mm)	4
29	3207534	QuadAir Goal Bar Red	2
30	3207536	QuadAir Goal Bar Green	2
31	3704009	Play Field Aeresol Polish (non-ammonia)	1
32	616030003	Hockey Mallet (Orange) w/Rubber Grip	4
33	616030002	Hockey Mallet (Blue) w/Rubber Grip	4
34	3399184	Barron Pucks	20
35	3612400	QuadAir LED Game Over Panel	4
36	3612398	QuadAir LED Countdown Timer Circle	1
37	3301354	Corner Mallet Holder	4
38	3601216	European Power Cord	1
39	3605107	Isolation Transformer 220V	1
40	3202118	Short Lock Assembly	8
41	3607070	QuadAir Motor Version 3 (1 3/8)	4
42	616030046	Coin Mech Faceplate	4
43	3607059	220V Blower Motor	1
44	3213517	Power Cord Security Clip	1
45	3612396	QuadAir Multi-color Interior LED Strip for Rails	8
46	3612394Quad	QuadAir Main PCB-B606 Blue Back	1
47	3712120	Cash Box	1
48	3213522	QuadAir Goal Gate Main Gear	4
49	3207544	QuadAir Rail 1728mm	4
50	3503270	QuadAir Side Decals	12

Ref #	Part #	Description	Qty
51	3399160	Blower Gasket	1
52	3303733	QuadAir LED Cover	8
53	3612399	Blue LED Ring for Puck Bay	4

How to fix the goal gate.

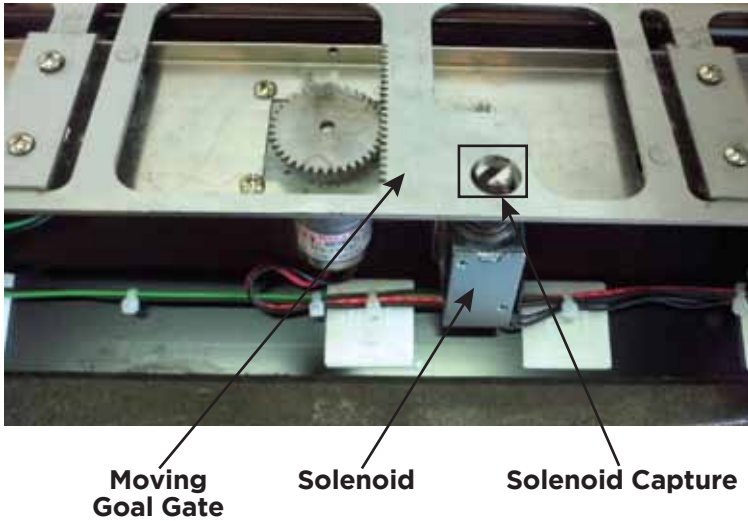

If the gate is clicking, it is because the solenoid is not catching in the Solenoid Capture hole. During shipment and installation the solenoid can bend inward toward the gate. This results in the solenoid not catching in the capture hole. To remedy pull the solenoid and slightly bend the bracket down, away from the gate until the solenoid is completely in the capture area and stops the goal gate from “clicking”. The clicking noise is the sensor switch not getting the information to “lock” by the solenoid.

Instructions:

- 1) Remove gate from table
- 2) Bend bracket down
- 3) Ensure proper alignment between solenoid and solenoid capture hole.

Goal Gate Troubleshooting Manual

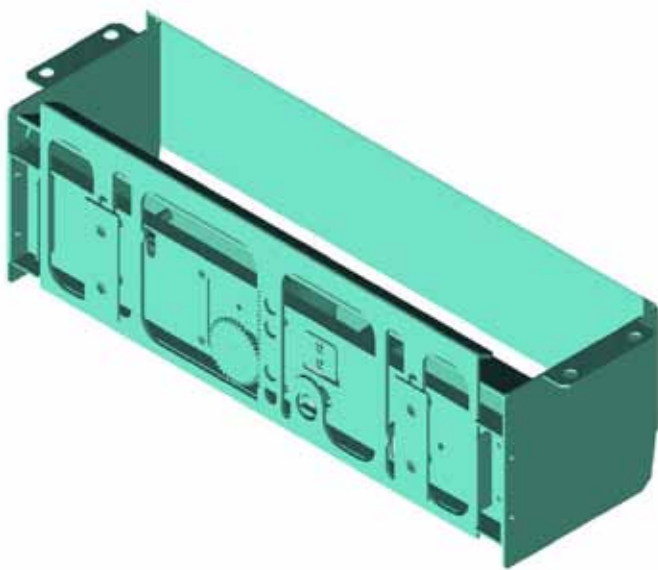

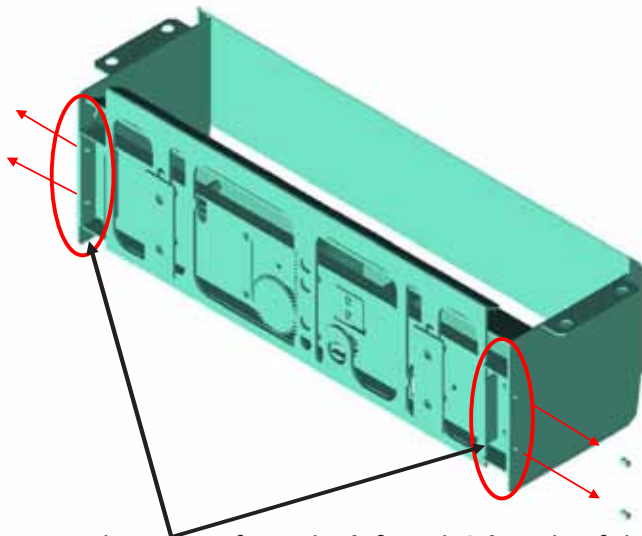

- Remove the screws from the **left** and **right** side of the goal gate assembly

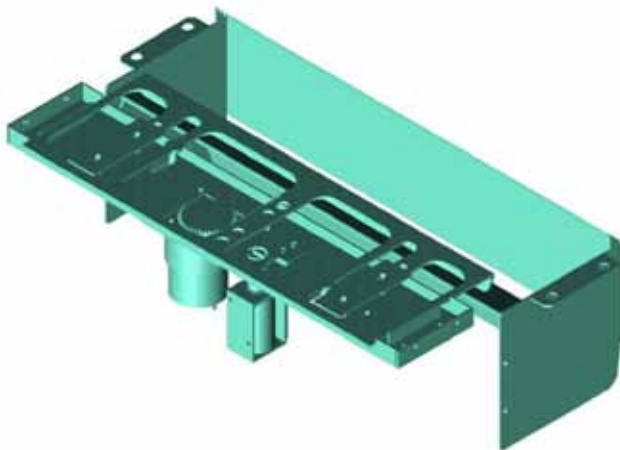

- The internal parts of the goal gate assembly will now be exposed

- Remove all **four** screws

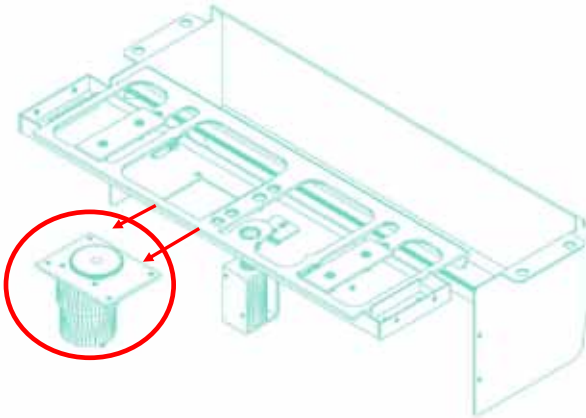
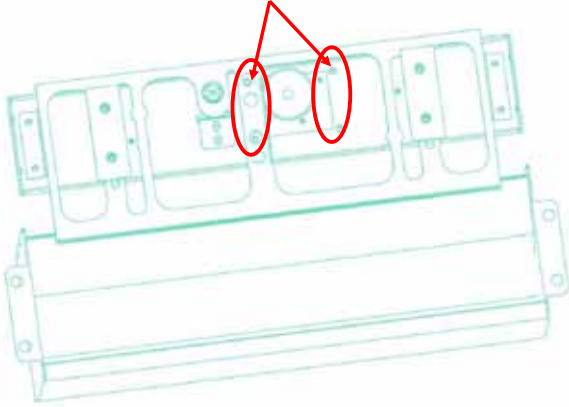

- Remove the motor

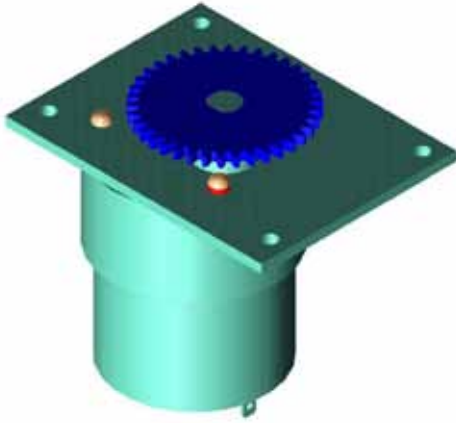

- Enlarged motor

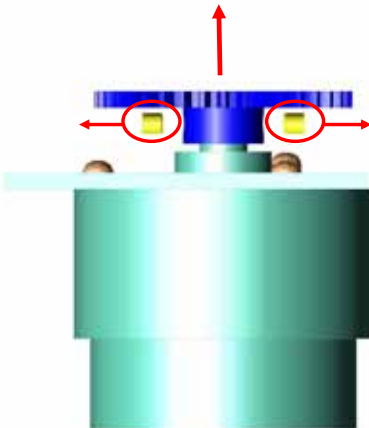

- 1) Remove the gear screws using an Allen Key
- 2) Pull the gear straight up

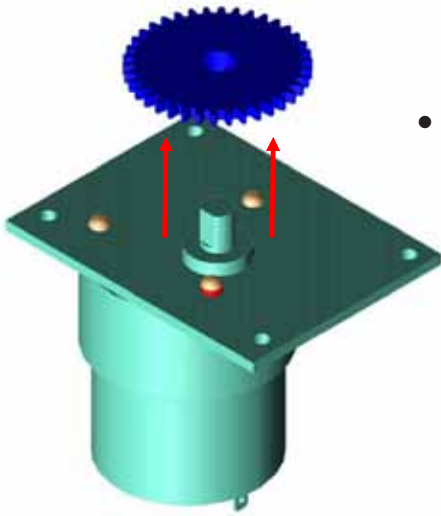

- Pull up to remove the gear

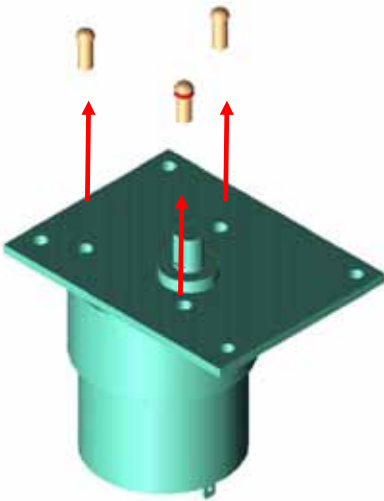

- Remove all three screws

- Fully detached motor

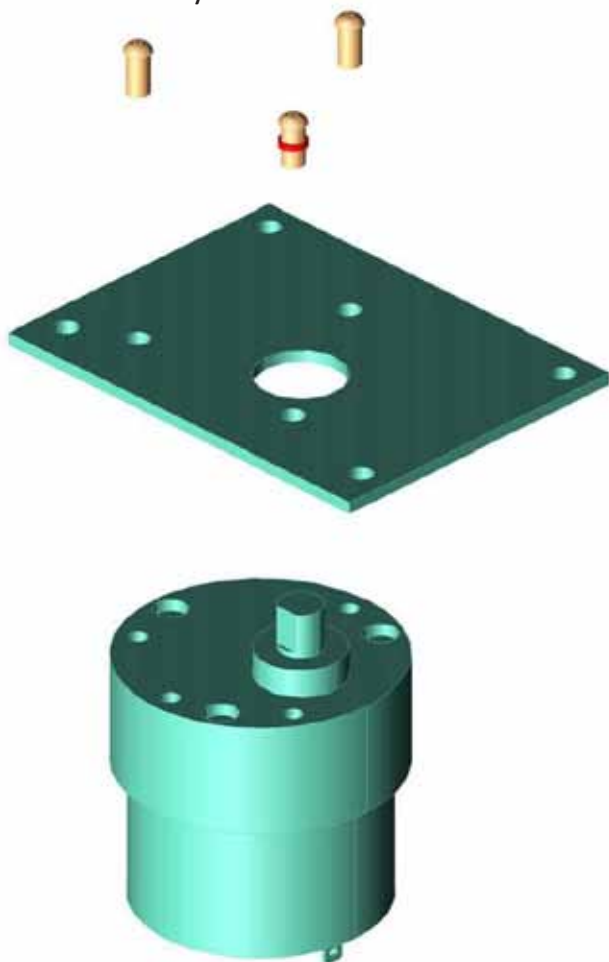

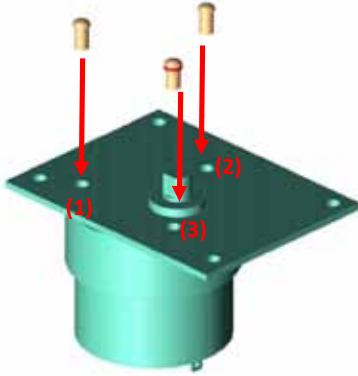

Attention:

Please note that there are **two** different size screws used on the QuadAir motor. Screws (1) and (2) are longer than (3), and they must all be placed back into the same holes they came from. A misplaced screw will damage the internal workings of these motors. Please see the attached pictures and contact the Barron Games service department at (716) 866-0054 with any questions.

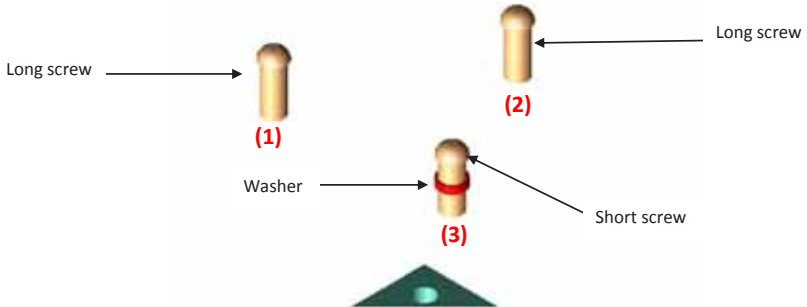
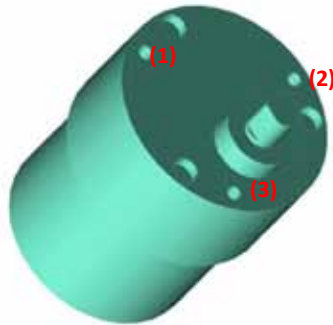

**For Spares and Technical
Service please contact
SEGA TOTAL SOLUTIONS.**



SEGA TOTAL SOLUTIONS

42 Barwell Business Park
Leatherhead Road
Chessington
Surrey
KT9 2NY
United Kingdom

+44 (0)208 391 8072

technical@sega.co.uk



84 Aero Drive | Suite 4 | Buffalo, NY 14225 USA
Phone: 1.716.866.0054 | Fax: 1.716.630.0054 | www.barrongames.com